

Specification

Pad-Mounted Capacitor Bank with Dual Fusing Integral Load-Interrupter on Line-Side Fuse Mountings

I. General

This specification covers the design requirements for a pad-mounted capacitor bank with dual fusing (i.e. two sets of fuses). One set of fuse mountings on the line side are equipped with an integral load-break interrupter capable of interrupting up to 800kVAR (single phase) under emergency conditions, but are not to be utilized as the normal means for switching the capacitor bank. The set of fuses in the load-break mountings provide protection for the capacitor bank. The second set of fuses is bolted-style current-limiting fuses that are bolted to the bus on the line-side of each capacitor and provide current limitation to guard against capacitor-tank rupture. The components shall be designed, manufactured and tested to meet the industry standards applicable to each of the specific components in the capacitor bank.

II. Capacitor Bank Ratings

The ratings for the capacitor bank are specified as follows:

- A. Capacitor Bank Size:
1200kVAR or 1800kVAR as described in the specific request for bid or purchase order involved.
- B. Operating Voltage:
12.47kV Y/7.2kV Grounded Y
- C. Basic Insulation Level:
95kV BIL
- D. Bank Connection:
Grounded Wye
- E. Capacitor Switch:
200 amperes Continuous
200 Amperes Load-Break
- F. Load-Break Fuse Mountings:
200 amperes Continuous
800kVAR Load-Break (single-phase)
- G. Non-Load-Break Fuses:
Current-Limiting Bolted Fuses

III. Capacitor Bank One-Line Diagram

The capacitor bank is to be configured as illustrated by the one-line diagram in Figure 1 below. Labels illustrating the one-line configuration are to be provided on the inside of each compartment door.

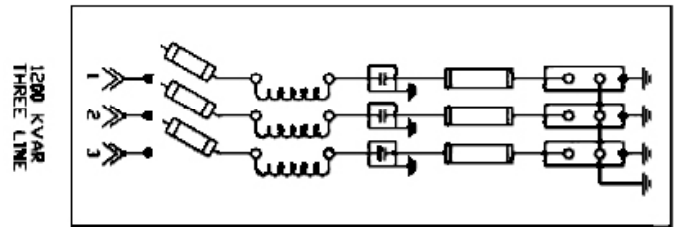

Figure 1. One-line diagram for 1200kvar capacitor bank

IV. Components

A. Line-Side Fusing and Cable Terminations

1. Cooper DBU, S&C SMU-20, or approved equal with an ampere rating of 125E and a Standard Speed Time-Current Characteristic (TCC) curve fuse unit shall be provided for the 1200kVAR capacitor bank and S&C SMU-20, Cooper DBU or approved equal with an ampere rating of 175E and a Standard Speed Time-Current Characteristic (TCC) curve fuse unit shall be provided for the 1800 kVAR bank.
2. The fuse mountings shall be supplied complete with an integral load interrupter, fuse-unit end fittings and fuse units.
3. There shall be insulating barriers at both sides of each fuse mounting that shall provide phase isolation from the adjacent fuse mounting. There shall be a dual-purpose barrier positioned to hang in the front of each fuse mounting and, with the fuse open or removed, the barrier shall be capable of being re-positioned on slides to isolate the top connections of the fuse mounting from the bottom connections of the fuse mounting. Refer to Figure 2.

Specifications must be verified by factory.

4. 200 Amp universal bushing wells complete with dust covers shall be provided on the incoming terminals for connection of load-break inserts and separable insulated connectors.
5. The bushing wells shall be located at a distance 42" \pm 2" from the bottom flange of the enclosure to the centerline of the bushing well as shown in Figure 3.
6. All barriers shall be NEMA GPO-3 red polyester laminated-fiberglass sheet material and shall cover the entire compartment opening.
7. Each fuse-terminal adapter for connection of the cable-termination pad is to have a 1/2" minimum diameter galvanized-steel, copper, or copper-clad ground rod with a minimum length of 2" for attachment of personnel equipment-ground clamps. The ground rod shall be located so as to have a minimum of 3" circumferential clearance to the nearest live parts including cable terminators.
8. A stainless-steel parking stand shall be provided adjacent to each bushing well. The centerline of the parking stand shall be located at the same level above the enclosure bottom flange as the centerline of the bushing well. Each parking stand shall be equipped with means to install a #14 bare copper drain wire.

B. Inrush Current-Limiting Reactor

1. One 60 micro Henry reactor per phase shall be provided.
2. The reactors shall be installed on the load side of the load-break fuse mountings.

C. Vacuum Switch

1. Single-Phase Joslyn Versa Vac switch with manual trip lever located \pm 45° from the switch-mounting bracket.
2. The control cord shall be three conductors #14 AWG copper. Cable shall be protected by flexible conduit, metal cable tray or "snake-skin" type wire shield.
3. The switch and control-cord connectors shall be 5 pin/socket types.
4. The jumper from the switch to the fuse-support bus bar shall be solid-copper bus bar or equivalent stranded-copper and shall be left disconnected on the switch side for shipment.

D. Capacitor

1. For the 1200kVAR bank, provide one 400 kVAR unit per phase. 400 kVAR capacitor units shall be protected by Cooper Power Systems, Type X-Limiter, 8.3KV, 80 Amp current-limiting fuses (catalog #83F 080 – IVBT). Any connecting cable or bus shall be disconnected from the capacitor unit to prevent damage during shipment. And, the fuse units shall be secured separately in the unit for shipment.
2. For 1800kVAR banks, provide two 300 kVAR or one 600kVAR unit per phase. Any connecting cable or bus shall be disconnected from the capacitor unit to prevent damage during shipment. And, the fuse units shall be secured separately in the unit for shipment. The fuse leader shall be tied back on itself to prevent damage during shipment. It shall not be connected to the capacitor unit at the time of shipment.
3. Capacitor units shall be either ABB (2GUA072400C220) or Cooper Power System (CEP170A6). The use of GE capacitor units (98L106WC62) are not approved for pad-mounted capacitor banks.

E. Ground Bus

1. The ground bus shall be 1/2" x 2" round edge copper bus bar, and shall run from the compartment door as shown on the layout sketch. Except as noted, the following items shall be connected to the bus with a minimum #2 stranded, bare, copper wire.
 - Voltage transformer (VT) base.
 - Capacitor bank ground point.
 - Mounting frames of capacitors and vacuum switches.
 - Voltage transformer secondary winding with #6 AWG copper wires.
2. The ground bar shall be mounted with the wide side mounted vertical and parallel to the enclosure front and shall have four welded on 1/2"- 13 UNC threaded nuts located as illustrated on Figure 3.
3. The front and rear compartment bus shall have a 1/2" x 6" stainless-steel, galvanized-steel, copper or copper clad rod for a personnel safety ground clamp. The rod shall have a 3" minimum radial clearance from any interference.

F. Voltage Transformer

1. The VT shall be molded rubber, indoor, General Electric type JVM – 5 (GE765x21G48) or approved equivalent.
2. One current-limiting primary fuse mounted in clips as part of the transformer shall be provided. The fuse shall be rated a minimum of one Amp. This fuse shall be designed and positioned for connection to the middle (center) bus.

G. Control

1. A meter socket shall be mounted on the inside of the front door as shown in Figure 3. The center-line of the meter socket shall be a minimum of 12" below the top of the compartment door.
2. The socket shall be an ABB six-jaw round-base meter socket with heavy-duty ring #01M0136G13 or approved equivalent.
3. Meter socket shall be wired to a terminal strip mounted in its own box. The bottom of the Terminal box shall have a hole with a bushing for the 2 conductor #14 cord from the current sensor.
4. The control circuit shall have a protective multi-breaker mounted in its own box.
5. The control equipment shall be located as close as practical using wire sized to maintain adequate control voltage at the vacuum switch. Copper conductor size shall be #6 AWG from the potential transformer to the terminal box, #10 AWG from the control socket to the terminal box and #14 AWG cord from the vacuum switches to the terminal box.

H. Enclosure

1. Enclosure maximum dimensions are 5' – 6" (H) x 6' – 6" (W) x 6' – 3" (D).
2. Primary conductors shall be a minimum size of #2 stranded copper.
3. The front panel shall have one removable 1/2" thick polycarbonate clear window barrier with handles to allow removal of switches without removing the front panel. The window barrier shall have openings large enough to permit operation using a "hot stick".

4. Vacuum switch mounting:

- a. To aid in its replacement, the switch shall slide out of the window on its mounting frame.
- b. The switches shall be mounted on a metal shelf that completely covers the primary fuse. Switch mounting hardware below the shelf shall be captive.
- c. The switch shall be mounted such that it cannot rotate about the mounting bolts.

5. Capacitors and their fuses shall be mounted and located to allow:

- a. The capacitor to be mounted in the upright position.
- b. A failed capacitor unit to be replaced with any of the acceptable manufacturer's units without additional materials.
- c. The replacement of a failed capacitor unit by use of a built – in tip – out mounting.

6. The rear door opening shall be fully covered with two NEMA grade GPO – 3 red polyester barrier panels with handles. Panels shall overlap at their center seam.

7. The minimum dimensions given on the layout sketch shall be maintained.

8. The enclosure shall be well ventilated with a minimum of three rows of louvers with two rows located at the top and one row at the bottom of all four sides. There shall be a minimum of six evenly spaced louvers per row. Each louver is to have a minimum of 1.5 square inches net ventilation area. A minimum of 108 square inches of ventilation shall be generated through the louvers.

9. The enclosure shall be painted and a resilient closed-cell gasket shall be applied to the bottom of the enclosure flange, galvanized, angle iron.

10. The enclosure shall be supplied with detachable lifting means and shall be provided with four detachable hold-down plates with slotted bolt holes.

11. Doors shall have a three point latching with a recessed penta – head bolt that must be secured before the lock can be installed. If the penta – head bolt is free to move in and out, it shall be spring loaded to hold it in the retracted position when it isn't threaded into the nut.



12. The nameplate shall include the following: Manufacturer, catalog number, kVAR rating, current and voltage rating, serial number, weight, and date manufactured.
13. Each door shall have a captive rod designed to hold the door in the open position range of 90° to 120°.
14. Door hinges and hinge pins shall be 304 stainless steel.
15. The unit shall be supplied with NEMA Standard #260 safety labels affixed to the inside and outside of the unit, as shown below. The "WARNING" label shall be attached to the outside of the unit, and a "DANGER" label to the inside of the unit. The labels shall meet the requirements of UL 969, "Marking and Labeling Systems".
16. The paint finish and security of the cabinet shall meet the latest revision of ANSI C57.12.28. The paint finish shall be light gray, #70 ANSI Z55.1.
17. The roof of the cabinet shall have one 5/8" diameter hole above the control socket compartment. This hole will be located 8" from front and 6" from side of cabinet and will be used to allow installation of an antenna. The hole shall be plugged for shipping. A removable 6"H X 6"W X 3"D cover with a 3/8" slot to allow routing of antenna cable shall be mounted below the 5/8" diameter hole to maintain integrity per ANSI C57.12.28.

I. Packing & Shipping

1. The unit shall be securely attached to a suitable pallet for shipping.
2. The unit shall be shipped on a flat bed trailer and positioned for side of vehicle unloading with the forks of a lift truck.

J. Bidder's Data

Bidder shall supply the following with the bid:

1. Supply detailed drawings of the equipment giving equipment layout, dimensions, and weight.
2. Actual capacitor unit outline drawing with dimensions and weight.
3. List and explain any exceptions taken to this specification. Any request for exception shall be accompanied by a set of drawings detailing the exception.
4. Any change/revision/substitution by supplier to approved unit shall be approved by the purchaser's Standards Department prior to acceptance.
5. Manufacturers that are not OEMs shall be responsible for warranting all equipment under this specification. These manufacturers shall not substitute equipment from other OEMs without the approval of purchaser's Standards Department.
6. All approvals from purchaser's Standards Department shall be in writing on purchaser's Standards Department letterhead. Verbal agreements shall not be acceptable at any time without confirmation in writing.

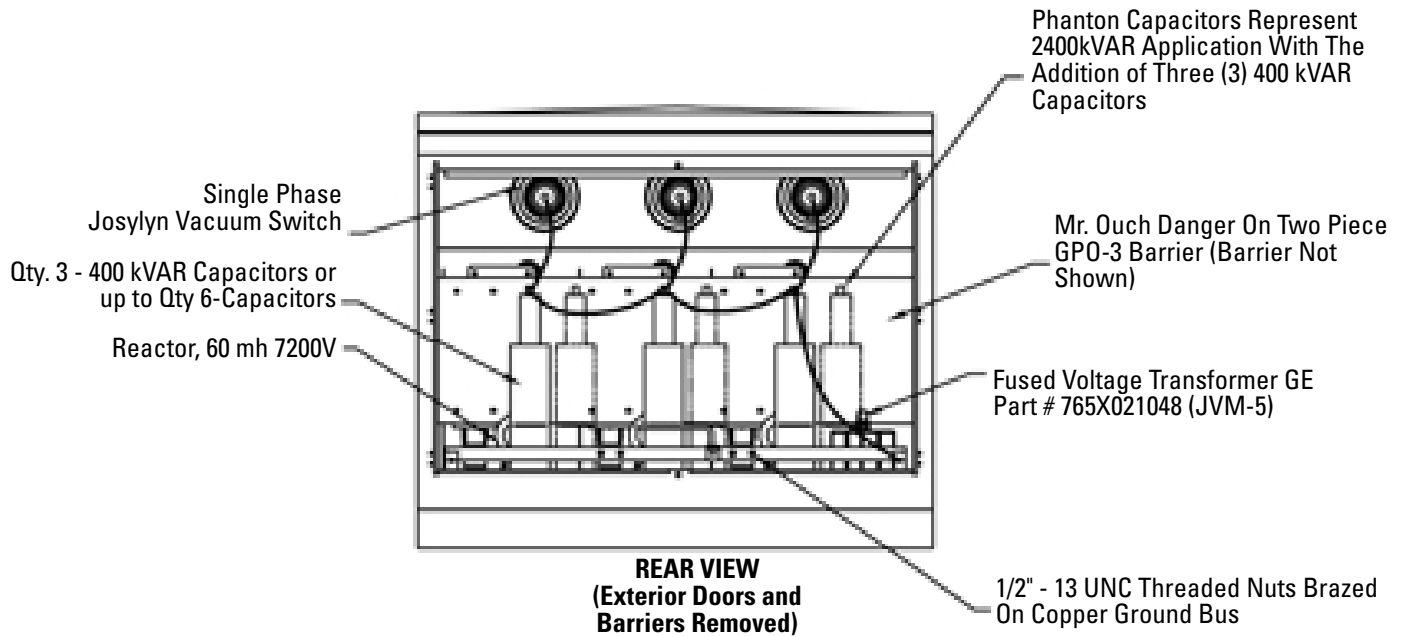

Figure 2. Rear view (capacitor side) with exterior doors and barriers removed.

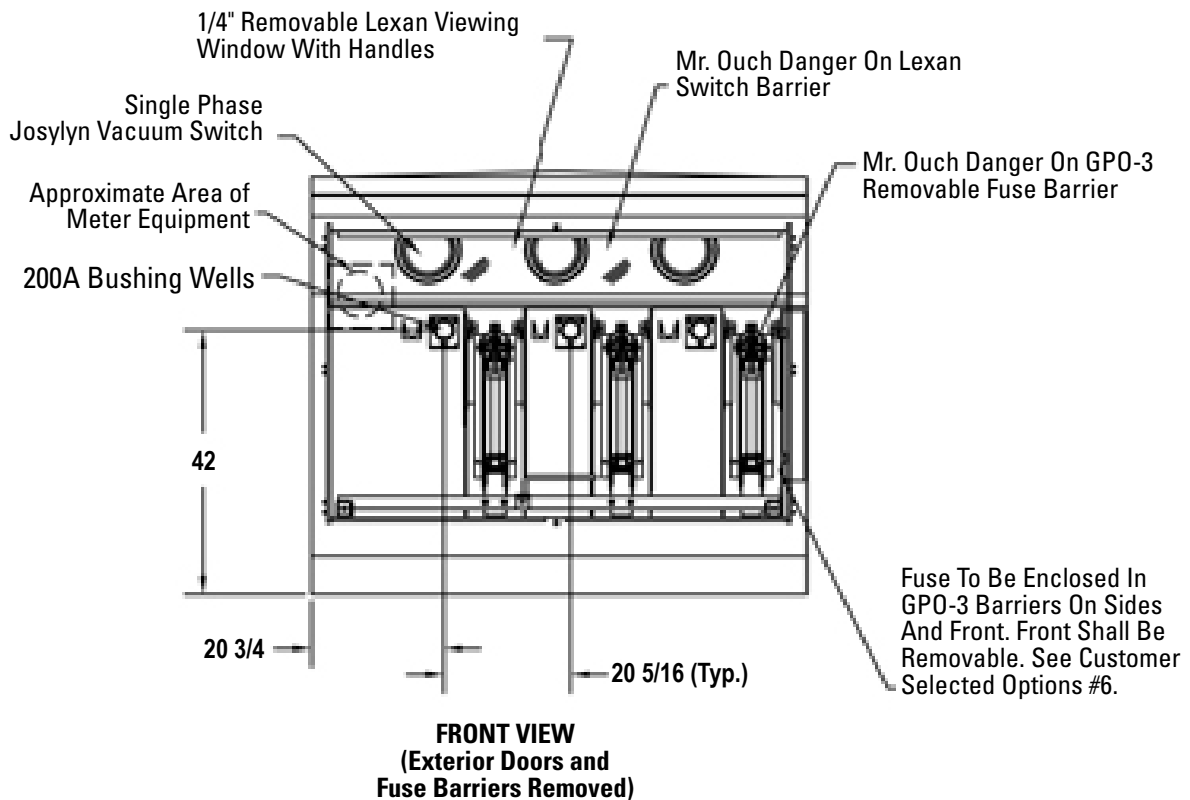

Figure 3. Front view (incoming side) with exterior doors and barriers removed.



This page intentionally left blank.



This page intentionally left blank.



This page intentionally left blank.

Specifications must be verified by factory.

Every effort is made to ensure that customers receive up-to-date information on the use of Federal Pacific products; however, from time to time, modifications to our products may without notice make the information contained herein subject to alteration.

